

Light Ball Clutch

from

Lifelong International Bowling, Inc.

"Worlds Leader in High Performance Specialty Parts"

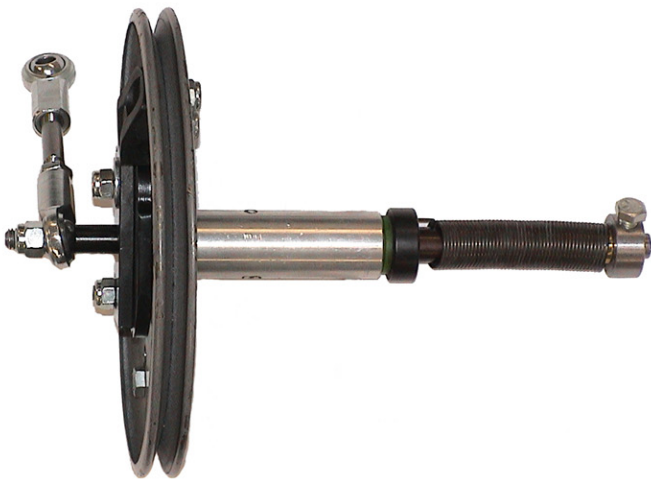

- Eliminates all light ball problems
- No more pins in the door
- Fewer moving parts
- No more expensive light ball sensor repairs
- No more delays or kick outs that are common with spring shocks
- Made from precision machined aluminum and cold finish steel
- Shafts and hub assemblies are nickel plated for longevity
- Little or no maintenance required
- Two models available to replace hydraulic and spring shocks or light ball sensors
- Patent pending

LL300-202 Instructions

Part #

Description

Part #	Description
LL 300-201	Replaces spring or hydraulic shocks on kickers, humpbacks, and mini-PBL's
LL 300-202	Replaces the light ball sensors on PBL's

Call Toll Free
1-877-235-8300
To Order Yours Today

 **LIFELONG
INTERNATIONAL
BOWLING, INC.**

"leaders in high performance specialty parts"

www.bowlingproducts.com

LIGHT BALL CLUTCH

Your new LIGHT BALL CLUTCH is designed to allow light balls to enter the ball exit without the delays and kick outs found with old fashioned spring shocks. The unit was designed to last for many years with little or no maintenance, nor expensive repairs as found with light ball sensors. The spring is the only part that may need replacing over time.

The LBC is mechanically simple with little chance of failure because the entire unit is made from precision machined aluminum and cold finish steel.

HOW THE LBC WORKS

The pulley itself rotates around like any normal pulley would. The inside hub rotates independently of the pulley. A link is attached to the inside hub and connects to the rudder arm casting. There is a light duty spring that allows the inside hub to follow the pulley around, thus moving the rudder arm back and forth as the pulley turns. The spring is very weak and it only takes a few ounces of pressure for a light ball to push the paddle out of the way, this can be accomplished because of the inside hub's independent rotation. When a pin enters the exit blocking the ball from entering, the pulley will continue to rotate. After one revolution (about two seconds) the pulley comes in contact with a stop on the hub creating a direct drive from the pulley to the rudder arm. Once the pin is knocked out the spring will reset the center hub to its normal position.

If a ball (regardless of weight) drifts off of the cushion near the exit or is stopped by a passing pin rolling on the carpet in front of the exit the momentum of the ball will be lost. If the paddle is just reaching the ball when this happens the unit is designed to hold the ball in place for a couple of seconds (one revolution). The paddle will then nudge the ball a couple inches from the exit in a controlled manner, move out of the way and allow the ball to enter the exit.

REDUCTION PULLEYS

The use of reduction pulleys to slow the paddle down is not always needed. The judgment call is yours and will depend partly on what kind of ball return system you have. We recommend reduction pulleys with HUMPBACKS and KICKER UNITS and sometimes on PBL's depending on how fast your rudder arm is moving. If you have slow back end motors with a small drive pulley and large clutch pulleys on your lift you may be satisfied with the LBC operation without a reduction pulley, regardless of what ball return system you have.

WHICH LBC UNIT TO USE

There are two LBC units to choose from. One unit (part # LL 300-201) is designed to replace either the old style hydraulic or spring shocks that are usually accompanied with the slim 1/4" drive belts. *If you are installing LL 300-201, then skip to page 5 to begin installation instructions.*



Figure 1

Note: If you are installing LL 300-201, make sure the tube that you will be using is the shorter one with the threads (see Figure 1). If not, you can order part # LL 300-223 (see Figure 2).



Figure 2

The other unit (part # LL 300-202) is a conversion unit which uses the existing drive pulley that runs the wider 3/8" belt usually accompanied by an existing Light Ball Sensor (to be removed for conversion). If you are installing LL 300-202, then turn to the next page to begin assembly instructions.

LBC ASSEMBLY INSTRUCTIONS

LL 300-202 (Replaces Light Ball Sensors)

PREPARING YOUR PULLEY

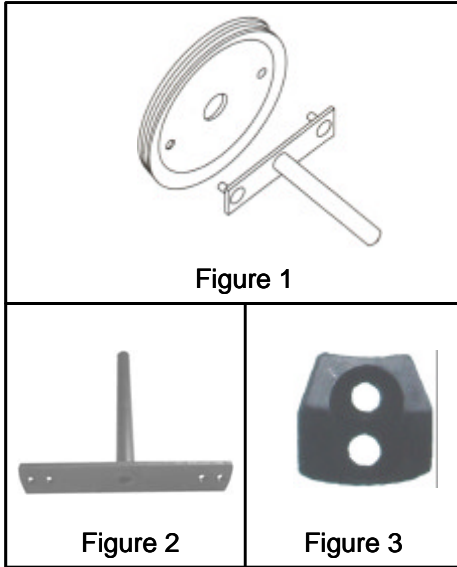

1. Remove your existing light ball sensor and crank pulley (070-011-097) from the machine (see figure 1).
2. Remove the crank shaft weldment (070-011-092) from the pulley
3. Bolt the new crank shaft (LL 300-221) to the pulley (see figure 2). Take note that there are four holes on the plate of the crank shaft. Once bolted on, drill out the outer two holes with a 5/16" drill bit.
4. Remove the bolt from one side of the plate and bolt on the plastic stop (LL 300-222) with the two flat head allen bolts provided (see figure 3). Remove the bolt from the other side of the crank shaft plate and move it to the outer 5/16" hole that you drilled.

PREPARING THE HUB ASSEMBLY

1. Slide the new LH end fitting (LL 300-219L) onto the crank plate bolt, then slide on a uniball washer (000-029-611) and the 3/8" nylock nut provided (see figures 1 & 2).
2. **IMPORTANT: Check the end fittings to make sure that the ball spins freely with no resistance. If there is resistance, the LBC will not work properly.**
3. Take 2 fibre washers and push them into the large hole in the center of the crank pulley (see figure 3) and slide another fibre washer onto the male crank shaft (see figure 4) and slide it up to the hub.
4. When you slide the male crank shaft into the female, the hub should spin "very" freely within it. If it does not spin freely, simply take a 7/16" drill bit and ream out the fibre washer you pushed into the crank pulley.
5. Once the shaft spins freely, lubricate the male shaft with a light oil (**no grease**) and insert the male shaft into the female.

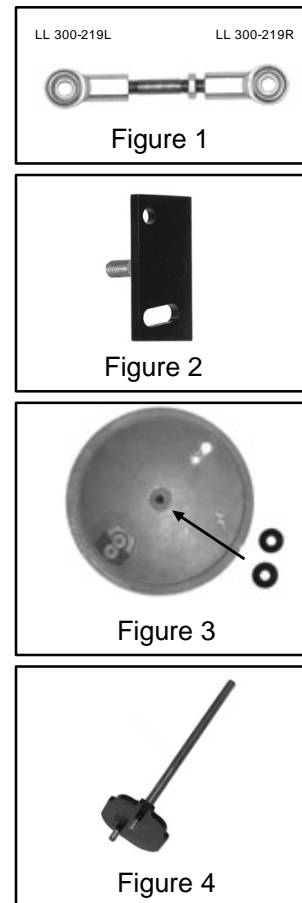

FINAL ASSEMBLY

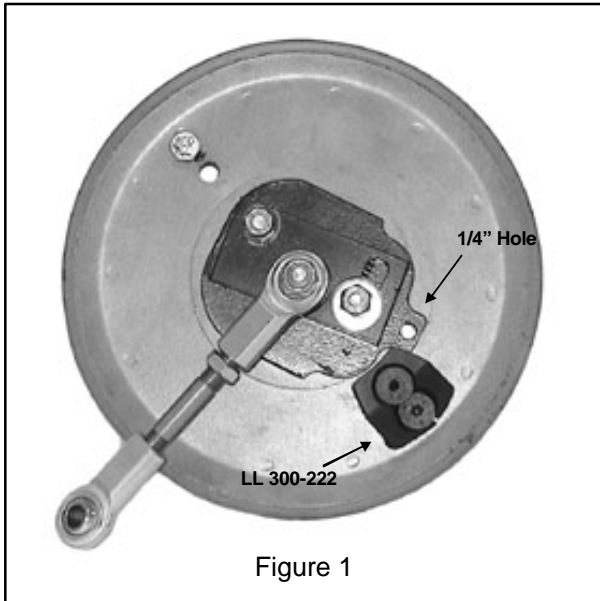

1. Turn the hub clockwise until the stop rests against the plastic stop (LL 300-222) that you installed (see figure 1).

2. Drill a 1/4" hole through the crank pulley using the hole in the hub as a guide.

3. Put the 1/4" X 2" bolt through the hole and secure with a nut to lock in place. This is your "keeper" bolt.

4. You will be replacing your existing tube (000-029-697) with the shorter one provided (LL 300-223). Slide the new tube on.

5. Secure the tube with the 5/8" spring collar (LL 300-215).

6. Slip the spring (LL 300-212) over the crank shaft and insert into the hole of the collar.

7. Slide on the brass bushing (LL 300-214) provided.

9. Slide on the 7/16" spring collar (LL 300-213) so that the spring fits into the hole. Turn the end spring collar clockwise **1 to 1-1/2 turns only** and tighten down.

10. Remove the "keeper" bolt and spin the hub all the way around and let go. It should spin freely and return to its stop position. Put the "keeper" bolt back in and begin installation.

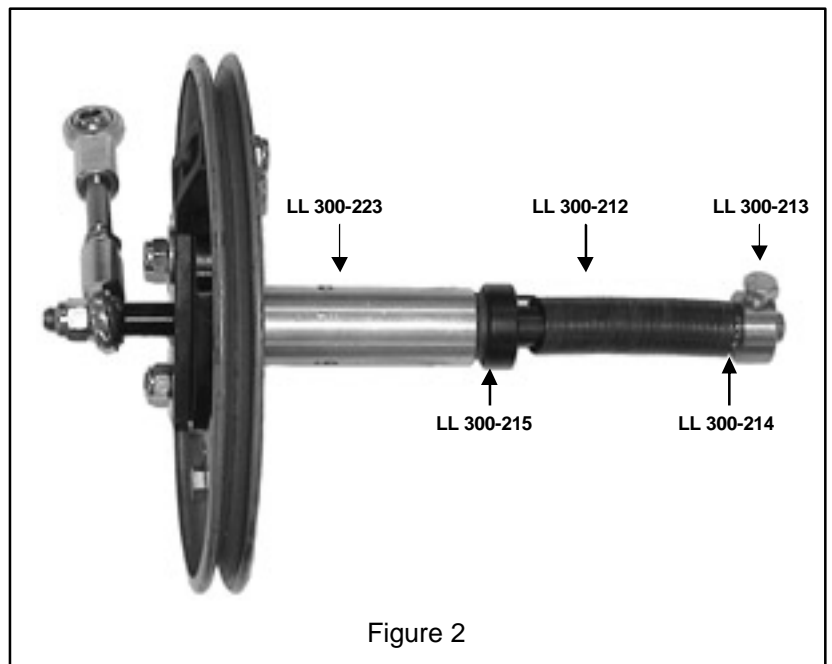

REMOVING THE OLD

1. Remove your existing crank pulley from the machine.
2. Remove the tube:
 - A. If you have the tube that has no threads, be sure that you have the shorter replacement tube on hand (LL 300-223).
 - B. If your tube is threaded with two large nuts, unscrew it from the outside with the nut behind the plow.

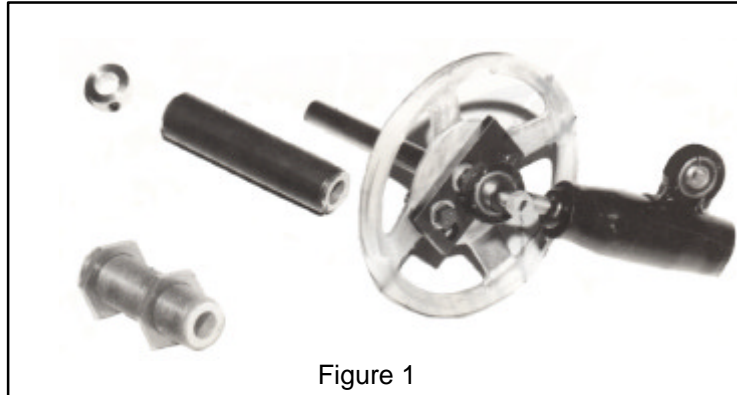

PREPARING THE UNIT

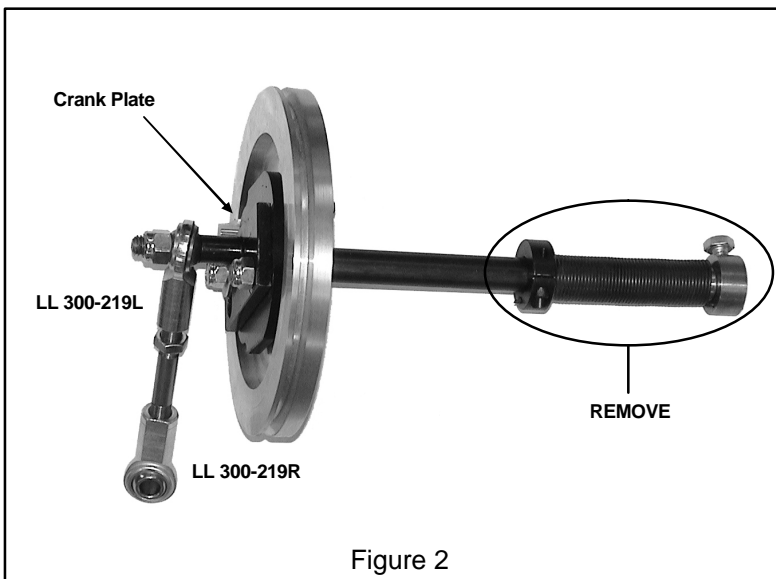

1. Be sure the “keeper” bolt is in. This is the 1/4” X 2” Hex Head.
2. Slide the crank plate to its inner most position. Only snug tighten the nylock nuts at this time.
3. Screw the end fittings (LL 300-219L and LL 300-219R) all the way in. Lubricate the end fittings with a light oil (**no grease**). Double check the end fittings at this time to make sure that the ball spins freely. If there is resistance, replace before installing.
4. Remove both collars (LL 300-215 and LL 300-213), the spring (LL 300-212), and the brass bushing (LL 300-214). Slide the tube you removed over the shaft of the LBC.
5. Remove the “keeper” bolt and slide hub assembly out to lubricate the shafts with a light oil (**no grease**). Reinsert “keeper” bolt.

INSTALLING THE UNIT

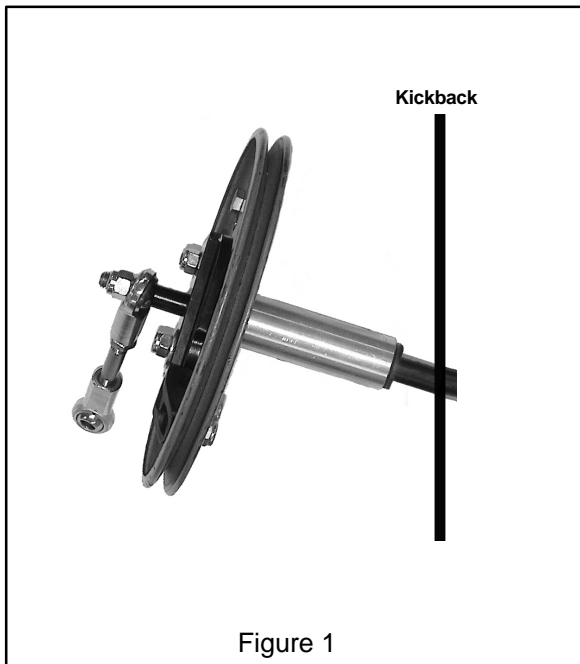

1. Angle the shaft of the LBC so that it will enter into the hole the tube fits into. Slide the tube through the hole (put nut on the threaded style tube) and install the spring collar (LL 300-215) to hold in place. Make sure that the LBC spins freely in the tube.

2. Line up everything. Start with a centered ball lift. The belt tensioner has a double pulley, line up the larger pulley to the ball lift and lock into place. Line up the LBC to the smaller pulley of the belt tensioner.

When lining up the LBC pulley to the belt tensioner pulley:

1. Swing the tensioner around so that the pulley is resting on the LBC.
2. Adjust the tube until the pulleys are lined up and tighten down.
3. Swing the belt tensioner back around so that it's hanging out of the way.

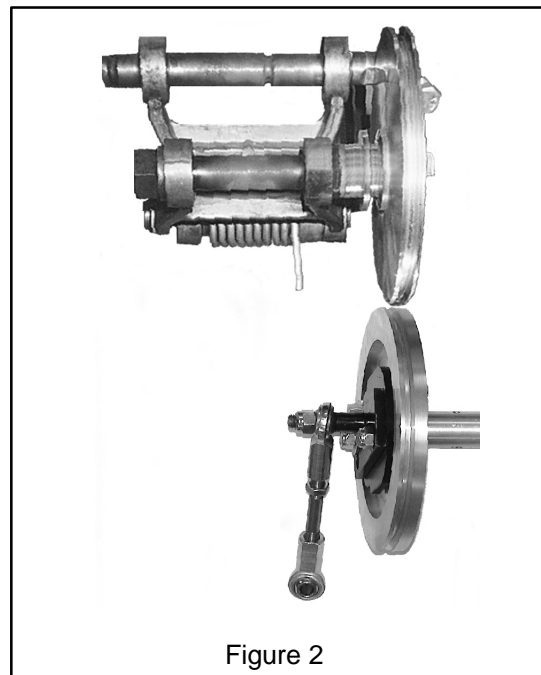

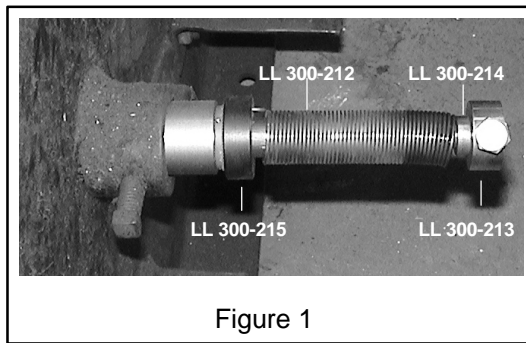

Figure 1

1. Install spring (LL 300-212) onto the LBC and into the hole of the spring collar (LL 300-215).

2. Slide on the brass bushing (LL 300-214) and outer spring collar (LL 300-213). Hold the LBC in place and turn the spring collar clockwise 1 to 1 1/2 turn only and tighten in place. Never tighten the spring more than this. The tension on the spring is not to knock pins out, but merely to allow the rudder arm to follow the pulley around.

3. Remove the “keeper” bolt.

4. Spin the inside hub, it should spin freely back into place. If it doesn't spin freely, check the spring collar (LL 300-213) and bushing (LL 300-214). If the collar is pressed too tight against the bushing, it could bind. Simply loosen and slide the collar a hair away from the bushing and retighten without releasing spring tension.

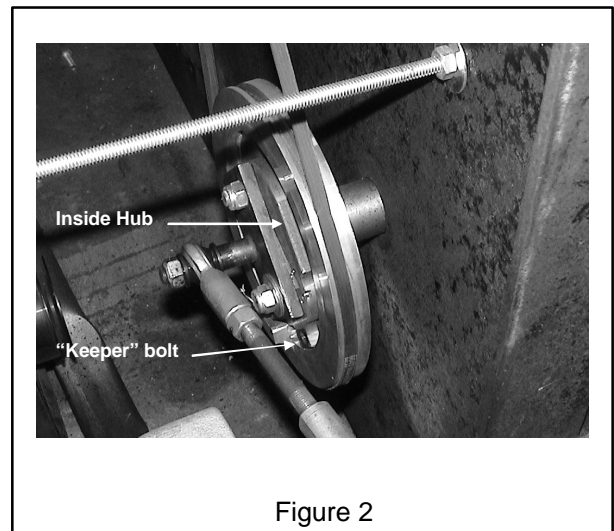

Figure 2

ADJUSTING THE LBC

1. Before beginning, be sure the crank plate is slid all the way towards the inner most adjustment and snug down only.

2. Be sure that the end fittings are turned all the way in to start with. One end fitting is left hand and one is right. Turning the shaft will increase or decrease the distance between the two fittings.

3. Slide the “keeper” bolt back in, but leave the nut off.

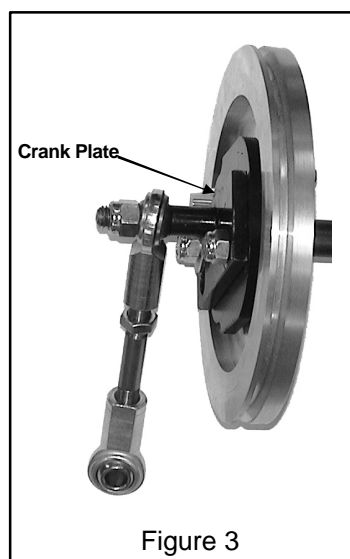

Figure 3

4. There are two belts that run the paddle off of the belt tensioner, start with new ones. The larger one (000-027-710) 36” goes to the ball lift from the larger pulley of the tensioner. The smaller belt (000-029-600) 33.5”, goes to the LBC from the smaller of the two pulleys.

5. Take the smaller belt and wrap it over the LBC and hang it from the tube. Once the link is put on, you will not be able to get the belt on.

1. Set the crank plate to its inner most adjustment for now, only snug one nut to hold in place. Rotate the LBC by hand until the crank plate bolt is closest to the pindeck. Push the rudder arm against the even machine (as shown in Figure1). Turn the shaft (LL 300-220) of the end fittings until it expands the fittings enough to be able to screw the bolt through the end fitting and into the rudder drive housing.

2. **IMPORTANT-** The type of rudder arm support you have will dictate how many uniball washers (000-029-611) you use. If you have the type support with the lip that generally used with light ball sensors (Figure 3), then you will need two uniball washers on the inside of the end fitting and one on the outside. If you have the type support with no lip, then use one uniball on each side of the end fitting (see figure 4). Failure to use the correct washers will usually result in binding issues. The angle movement of the end fitting requires clearance.

3. Turn the LBC by hand (either back and forth or around) with belts off and the keeper bolt in. The paddle will go back and forth as you turn the pulley. Providing the crank plate is at its inner most position, the paddle will only go part way toward the odd machine, then return.

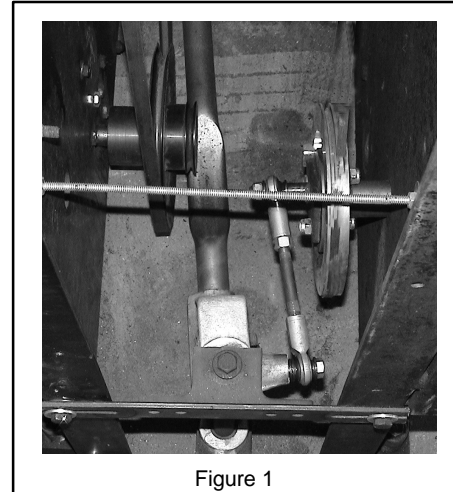

Figure 1



Figure 2

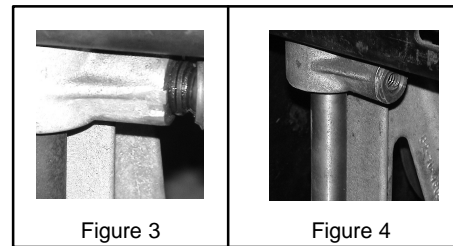

Figure 3

Figure 4

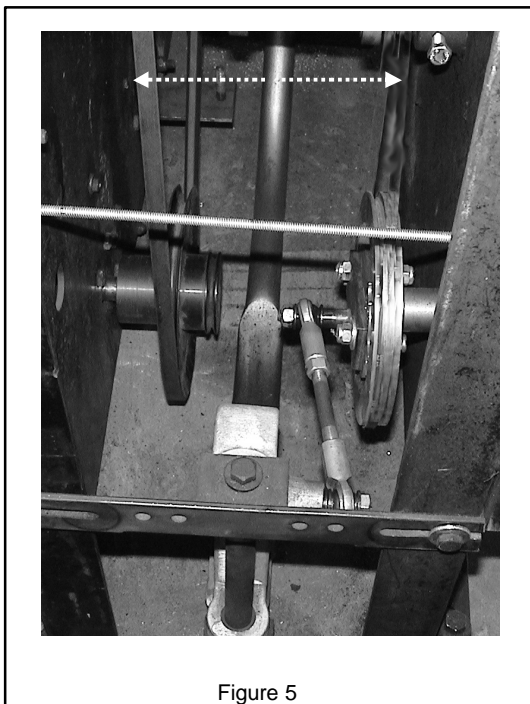

Figure 5

1. As you turn the end fitting shaft (LL 300-220) to lengthen the distance between the end fittings, the paddle will begin to move evenly between the machines. As you slide the crank plate adjustment further from the center, the paddle's over travel will increase. Make final adjustments turning the end fitting shaft (LL 300-220) and crank plate adjustment until the paddle is going evenly from machine to machine while just tapping (within a 1/16 inch) each kickback.

2. Tighten the jam nut on the end fitting shaft (LL 300-220) to lock into place.

3. Remove "keeper" bolt.

1. Make sure “keeper” bolt is removed.
Put belts on and turn on machine.

2. The rudder arm should be tapping each
kick back within a 1/16 inch.

3. Check adjustments.

